

AndyMark[®]

West Coast Drive Chassis

(am-4890)
Assembly Guide

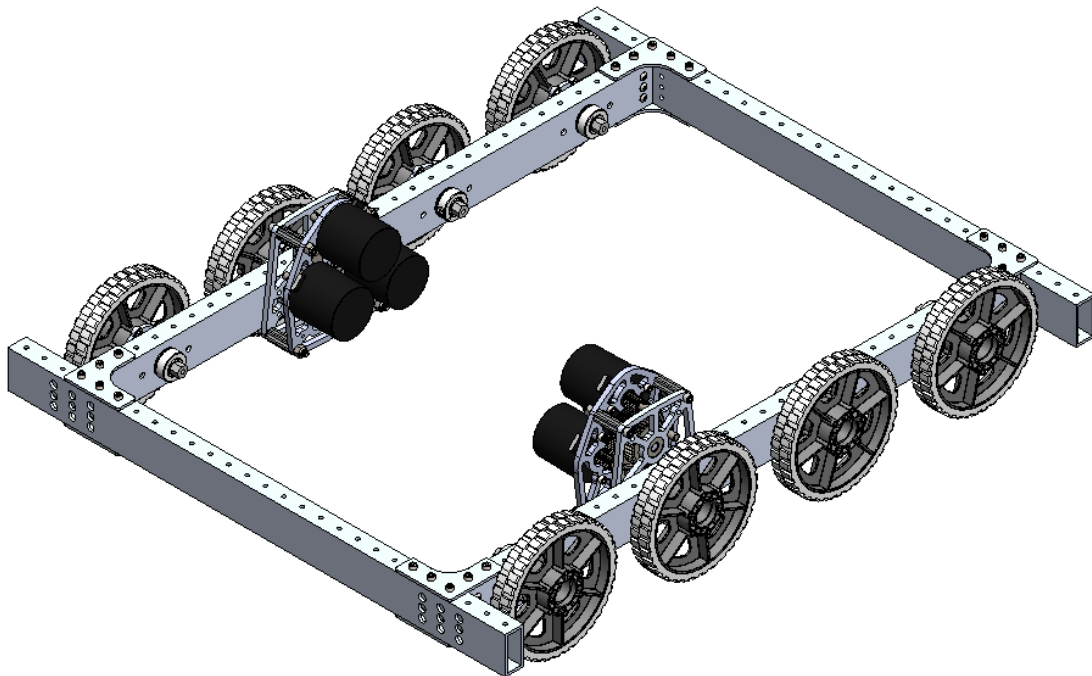

Revision #	Date	Author	Purpose
0	12/7/2022	E. Scime	Original Document

N. Massouda	12/7/2022
_____ Reviewer Name	_____ Date Reviewed

Need help with an AndyMark product? Contact us at support@andymark.com or (877)-868-4770.



Table of Contents

Pg. #	Section
4	<u>Parts & Tools</u>
4	Recommended Tool List
4	Frame Only Parts List
5	Chain-out-of-Tube Parts List
5	Chain-in-Tube Parts List
6	HiGrip Wheels Parts List
7	Performance Wheels Parts List
7	Gearbox Parts List
8	<u>Assembly</u>
8	Drive Pod Assembly (Chain-in-Tube)
12	Drive Pod Assembly (Chain-out-of-Tube)
16	Frame Assembly
18	<u>Appendices</u>
18	Appendix A: Wheel Configurations
19	Appendix B: Gearbox Configurations







Parts & Tools

Recommended Tools List

Component	Part #	QTY	Photo
Fold Up 12 Hex Set	am-3864	1	
3/8-7/16 Open-End Wrench	am-2745	1	
(Optional) DarkSoul #25 Chain Break	am-4024	1	



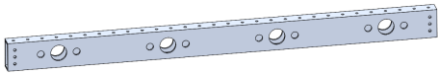

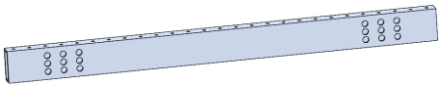
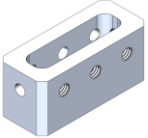

Frame-Only Parts List

Component	Part #	QTY	Photo
10-32 SHCS 0.5"	am-1542	20	
10-32 BHCS 0.375"	am-1588	24	
10-32 SHCS 2.5"	am-1024	16	
10-32 Nylock Jam Nut	am-1063	16	
90 Degree Gusset	am-3860	8	
Frame Drive Rail	am-4885	2	



Frame End Rail	am-4886	2	
2x1 Tube Plugs	am-4762	4	





Chain-out-of-Tube Parts List

Component	Part #	QTY	Photo
17 Tooth Sprocket	am-3999	6	
1/2" Hex Bearing	am-2986	14	
1/2" Hex Shaft Collar	am-1526	6	
0.375" Thick 1/2" Hex Spacer	am-3948-375	6	
0.125" Thick 1/2" Hex Spacer	am-3948-125	6	
Chain-out-of-Tube Hex Shaft	am-4884	6	
78 Link Chain Loop	am-4887	6	





Chain-in-Tube Parts List

Component	Part #	QTY	Photo
17 Tooth Sprocket	am-3999	6	







1/2" Hex Bearing	am-2986	14	
1/2" Hex Shaft Collar	am-1526	6	
0.250" Thick 1/2" Hex Spacer	am-3948-375	2	
Chain-in-Tube Hex Shaft	am-4883	6	
78 Link Chain Loop	am-4887	6	

HiGrip Wheels Parts List



Component	Part #	QTY	Photo
HiGrip Wheel, 80A	am-0940b OR am-2256	8	
Wheel Hub	am-4124	8	
10-12 Thread Forming Screw	am-1654	48	
1/4-20 BHCS 0.5"	am-1039	8	
1/4" Washer	am-1027	8	



Performance Wheels Parts List

Component	Part #	QTY	Photo
Performance Wheel	am-4177 OR am-4175	8	
Blue Nitrile Tread	am-4206	10ft OR 20ft	
1/4-20 BHCS 0.5"	am-1039	8	
1/4" Washer	am-1027	8	
Performance Wheel Tread Attachment Kit	am-4366	1	

Gearbox Parts List

Component	Part #	QTY	Photo
1/4-20 BHCS 0.625"	am-1681	4	
1/4-20 Nylock Nut	am-1102	4	
Gearbox (EVO Slim or EVO Slim for WCD)	am-4898 OR am-4891	2	



Assembly

Drive Pod Assembly (Chain-in-Tube)

Step 1

Press **four** ½" hex bearings (am-2986) into the bearing holes on **one** drive rail (am-4885) as shown. Make sure the middle two holes are lower than the holes at the end. The difference is slight (0.080"), but noticeable.

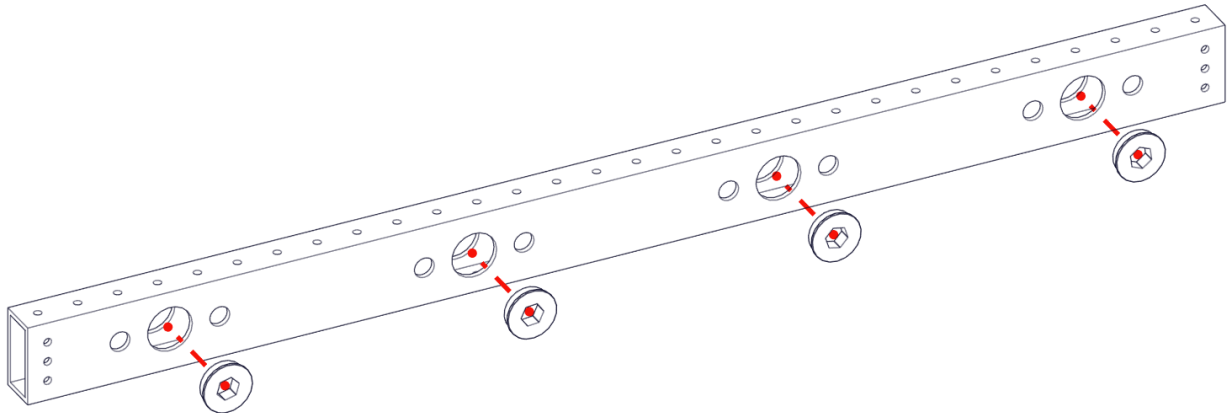

Step 2

Prepare **three** chain loops (am-4887) with **four** 17 tooth sprockets (am-3999) as shown. Insert into the tube from step 1 carefully, and pin one of the sprockets in place using one of the drive shafts (am-4883.)

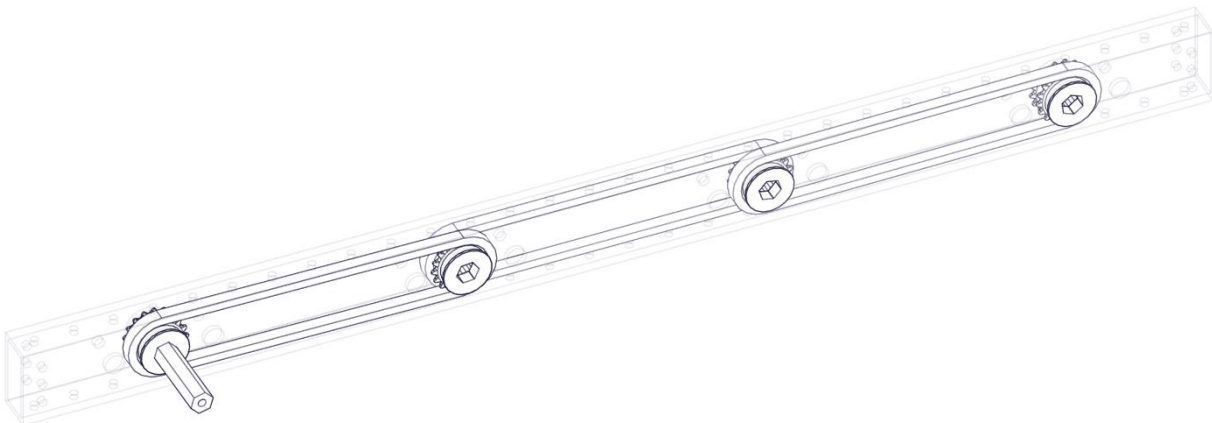

Step 3

Press **three** more hex bearings (am-2986) into the drive rail (am-4885) and insert the remaining drive shafts (am-4883) as you go. At the end of this step, there should be **seven** total bearings pressed in, **four** total sprockets, **three** chain loops, and **three** drive shafts attached. One space on the inside of the drive rail should be left open so your chosen transmission can be placed there later.

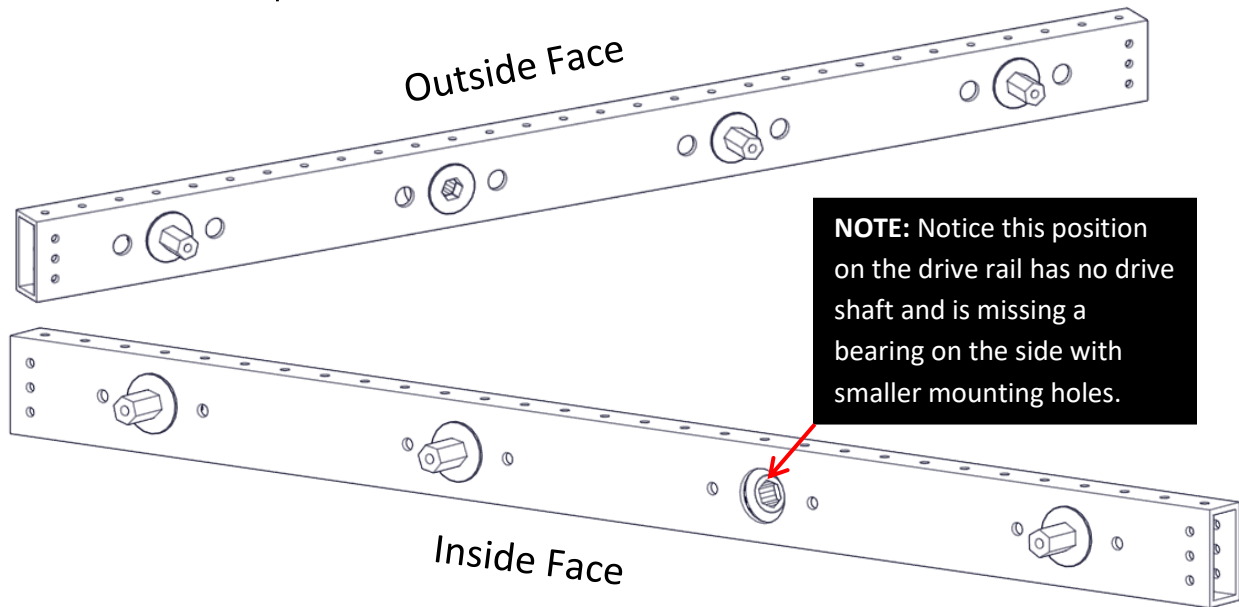

Step 4

On **each** drive shaft, secure a wheel [part number depends on what kit you have purchased. See **Appendix A** for relevant wheel preparation steps] using a 1/4-20, 0.5" long button head cap screw (am-1039), 1/4" washer (am-1027), and 1/2" Hex collar clamp (am-1526.) Ensure that the assembly is tight by pressing the shaft all the way through using the head of the bolt and tightening the collar clamp.

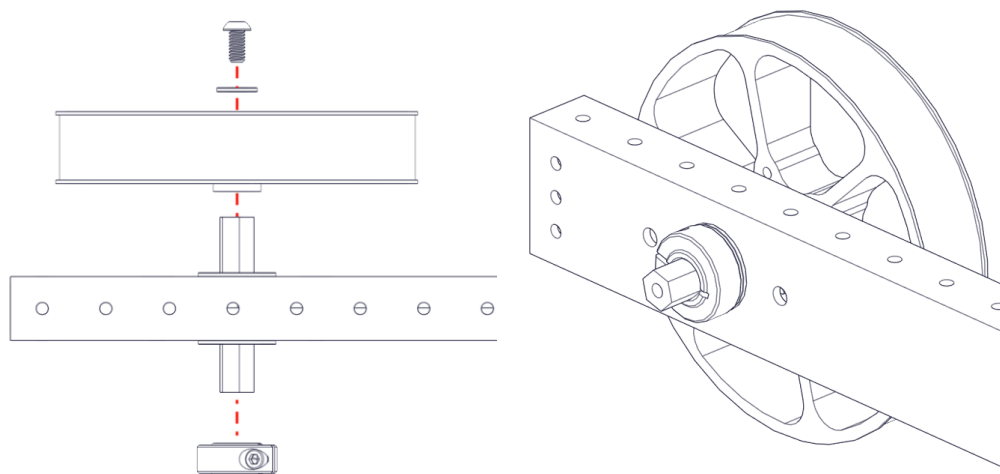

Step 5

Attach a gearbox [part number depends on what kit you have purchased. See **Appendix B** for relevant gearbox preparation steps] to the drive rail by inserting its output shaft into the one remaining unfilled position. Place a 0.250" long $\frac{1}{2}$ " hex spacer on the shaft before inserting it. Secure it via **two** $\frac{1}{4}$ -20 0.625" long button head cap screws (am-1681) and **two** $\frac{1}{4}$ -20 thin nylock nuts (am-1102).

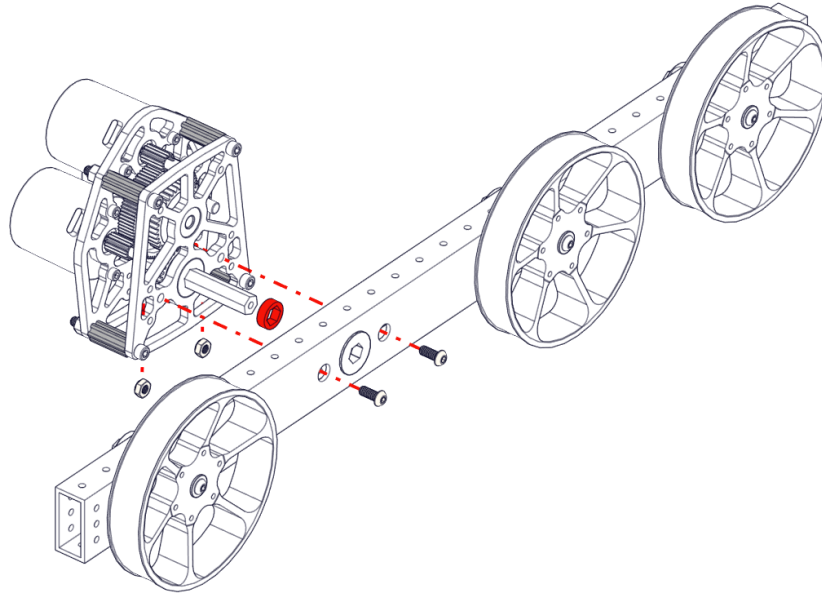

Step 6

Attach a wheel to the gearbox output shaft using a $\frac{1}{4}$ -20 0.5" long button head cap screw (am-1039) and $\frac{1}{4}$ " washer (am-1027). Depending on your wheel, it may be necessary to add a 0.125" long $\frac{1}{2}$ " hex spacer (am-3948-125) to fully secure the wheel as shown.

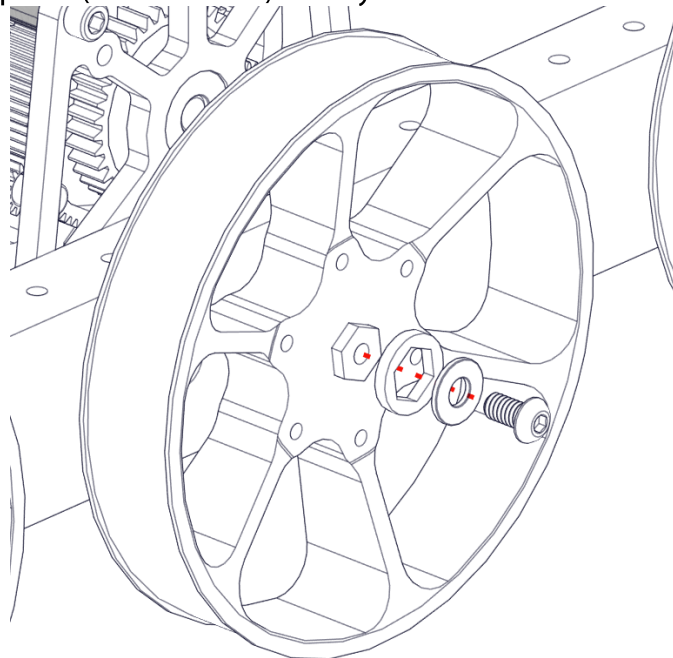

Step 7

Slide a 2x1 tube plug into **each** end of the tube. Secure them both with **six** 10-32 0.5" button head cap screws as shown. Do **not** place screws in the top and bottom holes at this time.

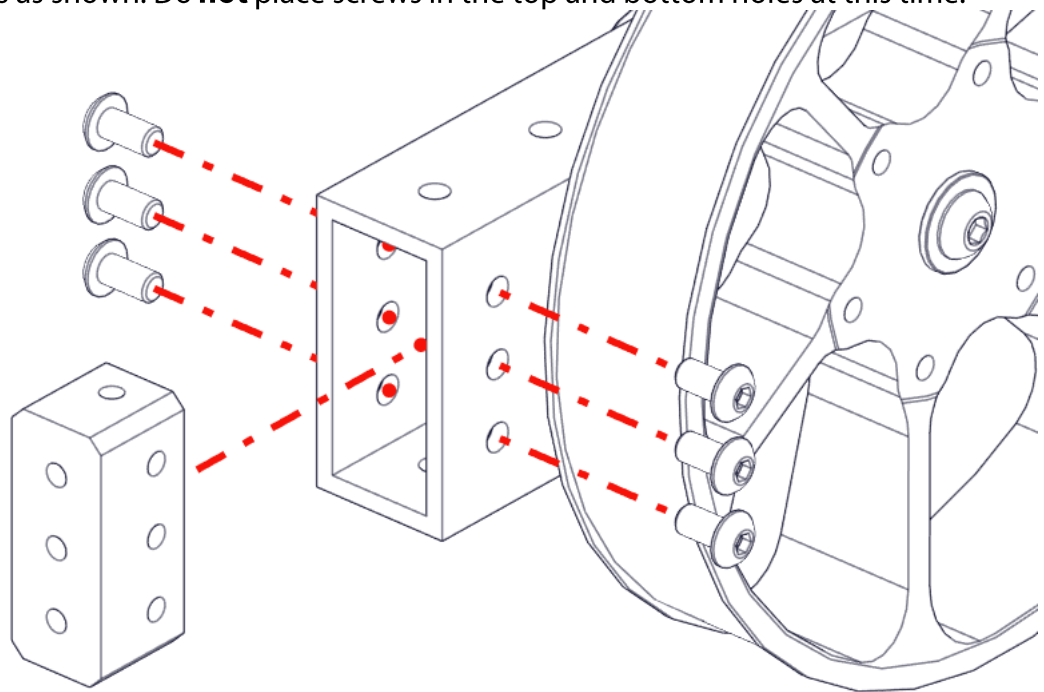

Step 8

Repeat steps 1 through 7 with the second drive tube. **Be careful!** The second drive tube should be a mirror image of the first. Make sure features like the lowered two holes remain lowered on the second drive tube. Your finished product should look like the image below.

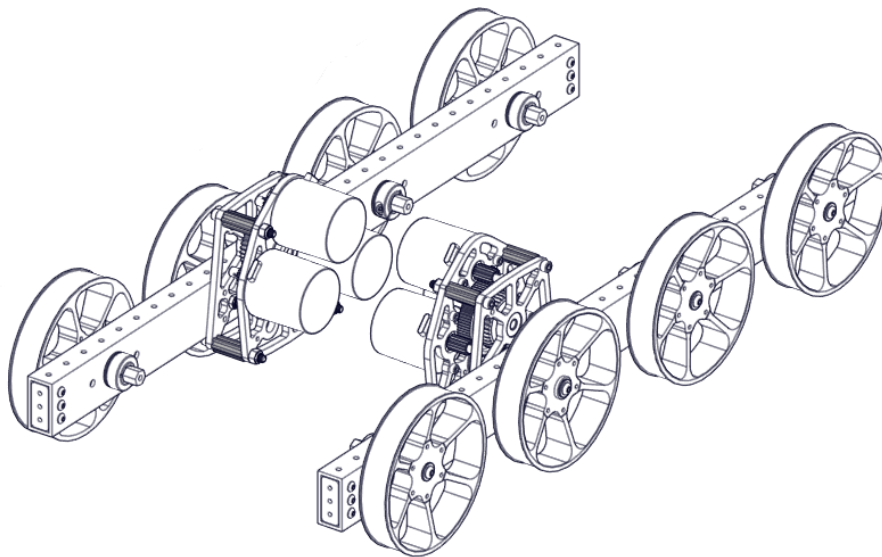

Skip ahead to Page 16 after completing this step!



Drive Pod Assembly (Chain-out-of-Tube)

Step 1

Press **seven** ½" hex bearings (am-2986) into the bearing holes on **one** drive rail (am-4885) as shown. Make sure the middle two holes are lower than the holes at the end. The difference is slight (0.080"), but noticeable.

NOTE: Notice this position on the drive rail has no drive shaft and is missing a bearing on the side with smaller mounting holes.

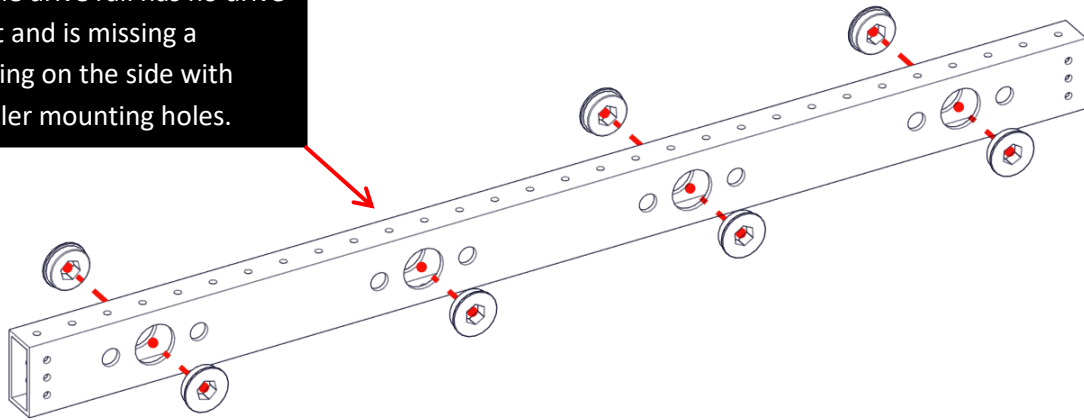

Step 2

Connect **two** chain loops (am-4887) to the sprocket inside your gearbox of choice. This can be done by assembling the gearbox with them around the sprocket or by breaking the chain and reconnecting it around the sprocket with a chain tool (am-4024.) Prepare the chain with **three** additional sprockets (am-3999) as shown.

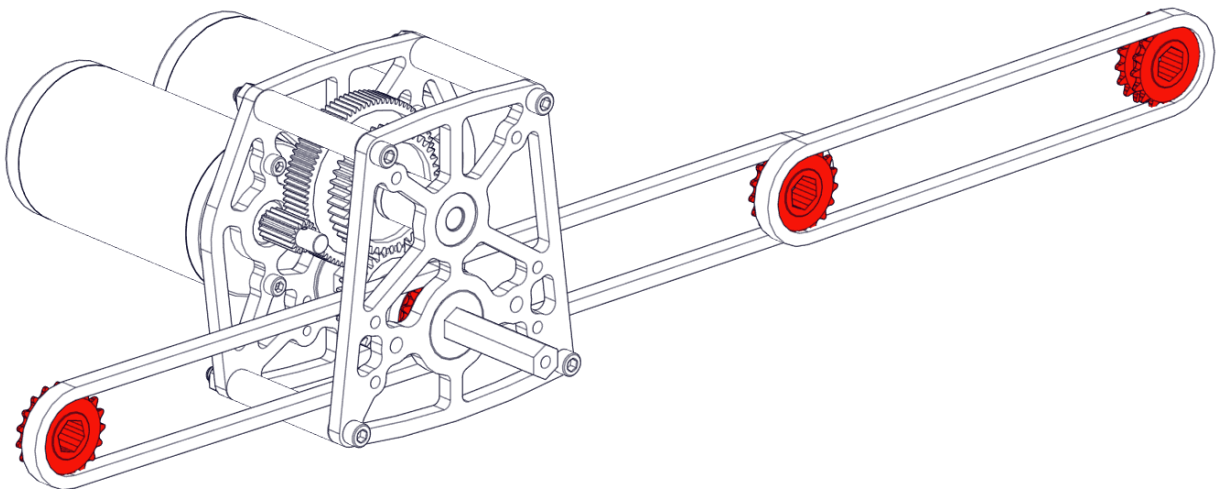

Step 3

Insert **three** drive shafts (am-4884) through the sprockets. Place a 3/8" long 1/2" hex spacer (am-3948-375.) Insert the assembly into the drive rail assembly. Attach the gearbox to the rail with **two** 0.625" long 1/4-20 button head cap screws (am-1681) and **two** 1/4-20 nylock nuts (am-1102.)

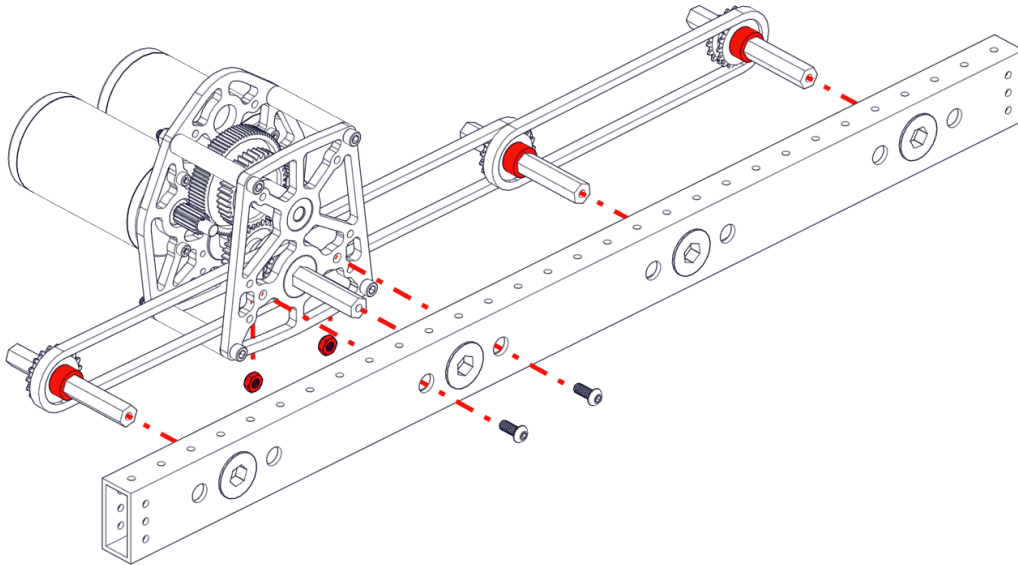

Step 4

On **each** of the **three** drive shafts, place **one** 0.125" long 1/2" hex spacer (am-3948-125) and a 1/2" hex collar clamp (am-1526) on the side with the sprocket. On the other side, place a wheel [part number depends on what kit you have purchased. See **Appendix A** for relevant wheel preparation steps] and secure it in place with a 1/4-20 0.5" long button head cap screw (am-1039) and 1/4" washer (am-1027.) Ensure that the assembly is tight by pressing the shaft all the way through using the head of the bolt and tightening the collar clamp.

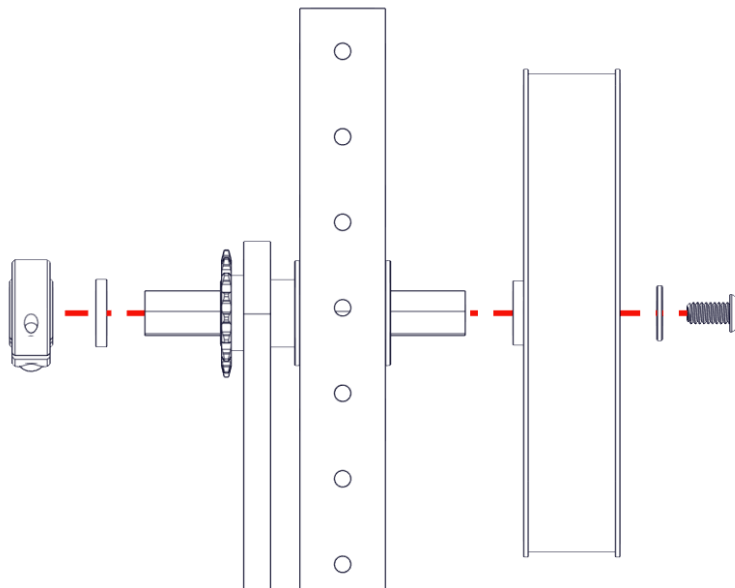

Step 5

Attach a wheel to the gearbox output shaft using a 1/4-20 0.5" long button head cap screw (am-1039) and 1/4" washer (am-1027). Depending on your wheel, it may be necessary to add a 0.125" long 1/2" hex spacer (am-3948-125) to fully secure the wheel as shown.

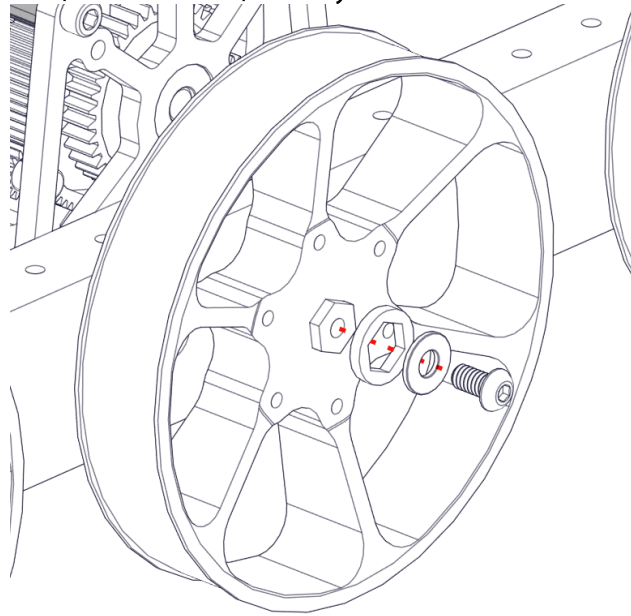

Step 6

Slide a 2x1 tube plug into **each** end of the tube. Secure them both with **six** 10-32 0.5" button head cap screws as shown. Do **not** place screws in the top and bottom holes at this time.

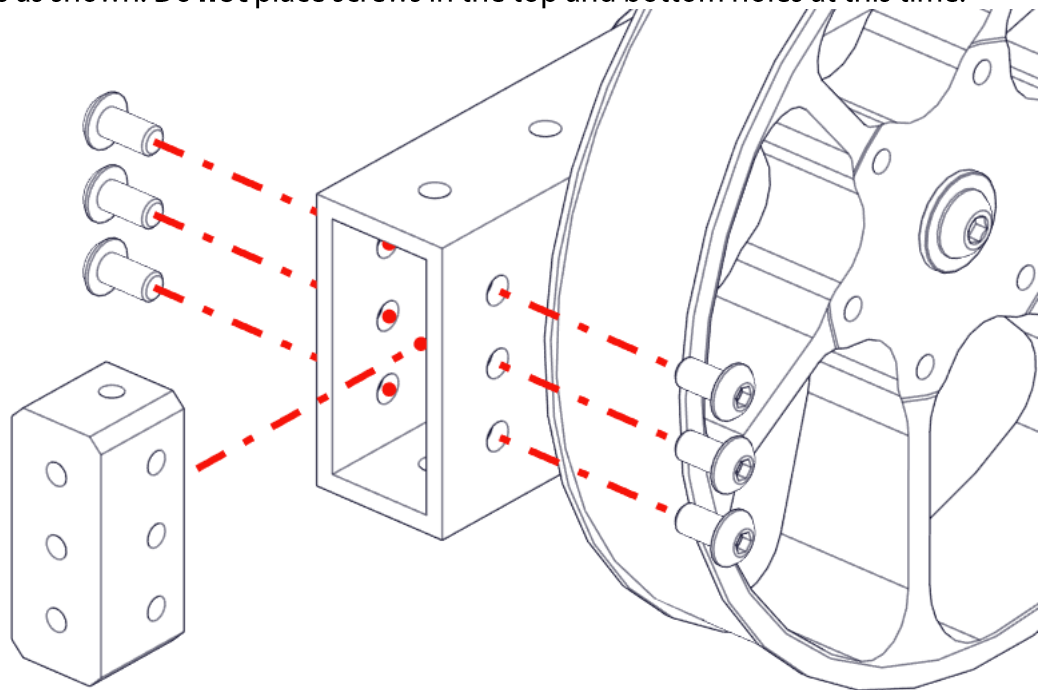

Step 7

Repeat steps 1 through 6 with the second drive tube. **Be careful!** The second drive tube should be a mirror image of the first. Make sure features like the lowered two holes remain lowered on the second drive tube. Your finished product should look like the image below

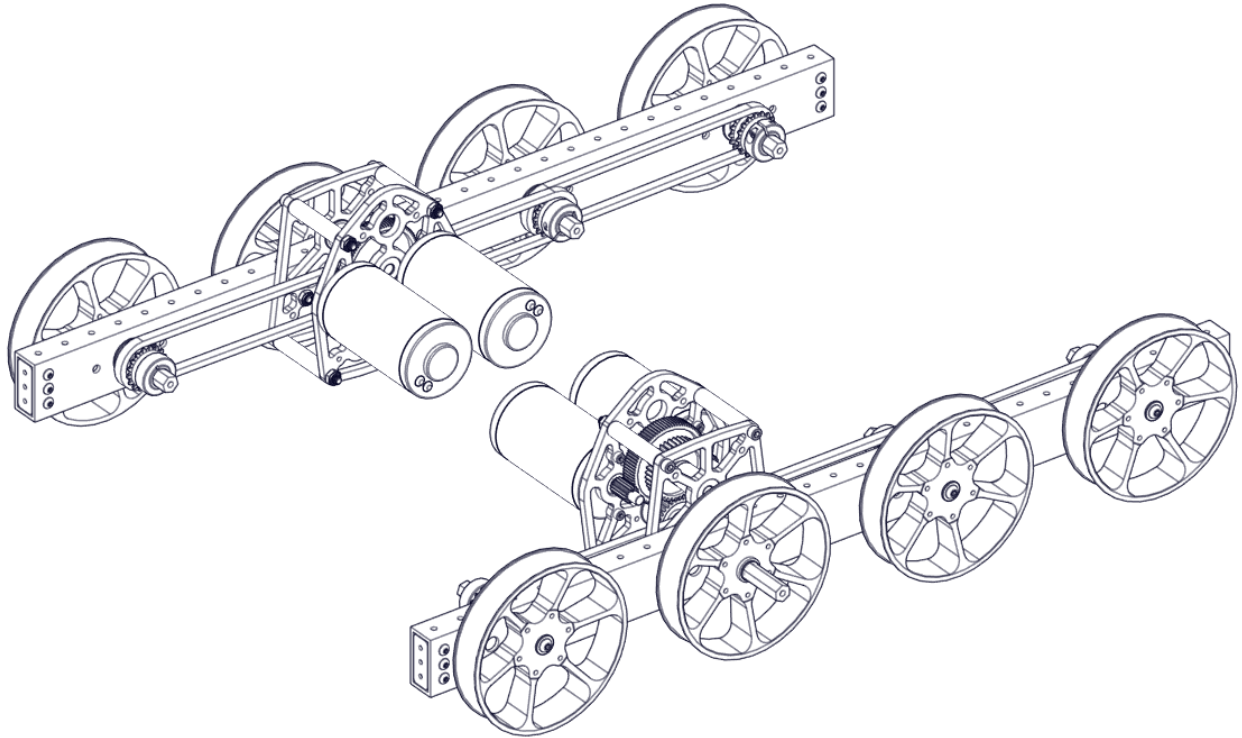

Frame Assembly

Step 1

At each end of the drive rails, use the **two** end rails (am-4886) to create the corners of your drivetrain. Secure in place with **twelve** 0.5" long 10-32 socket head cap screws (am-1542), three in each corner, as shown. If you're using your own wheels or want a slightly different aspect ratio drivetrain, you can connect the drive rails through one of the other two sets of provided holes.

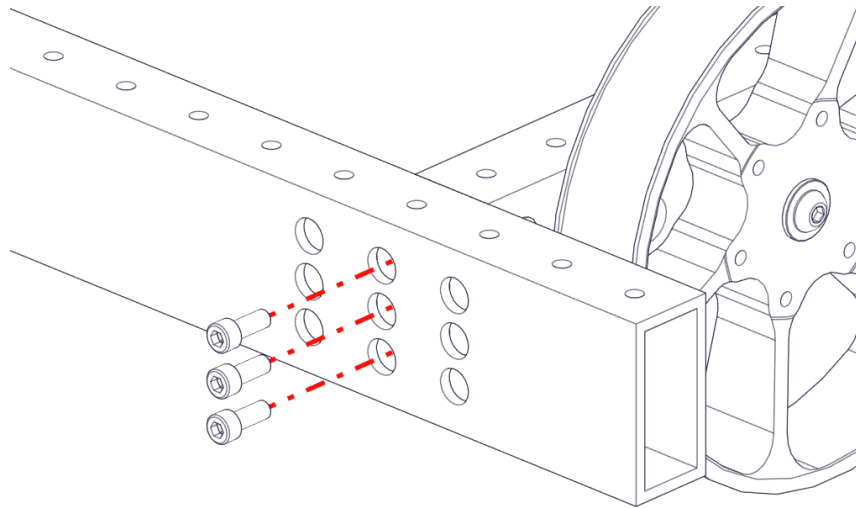

Step 2

In each corner, loosely attach **two** 90° gussets (am-3860) with **one** 0.5" long 10-32 socket head cap screw (am-1542.) This results in a total of **eight** gussets attached via **eight** screws as shown.

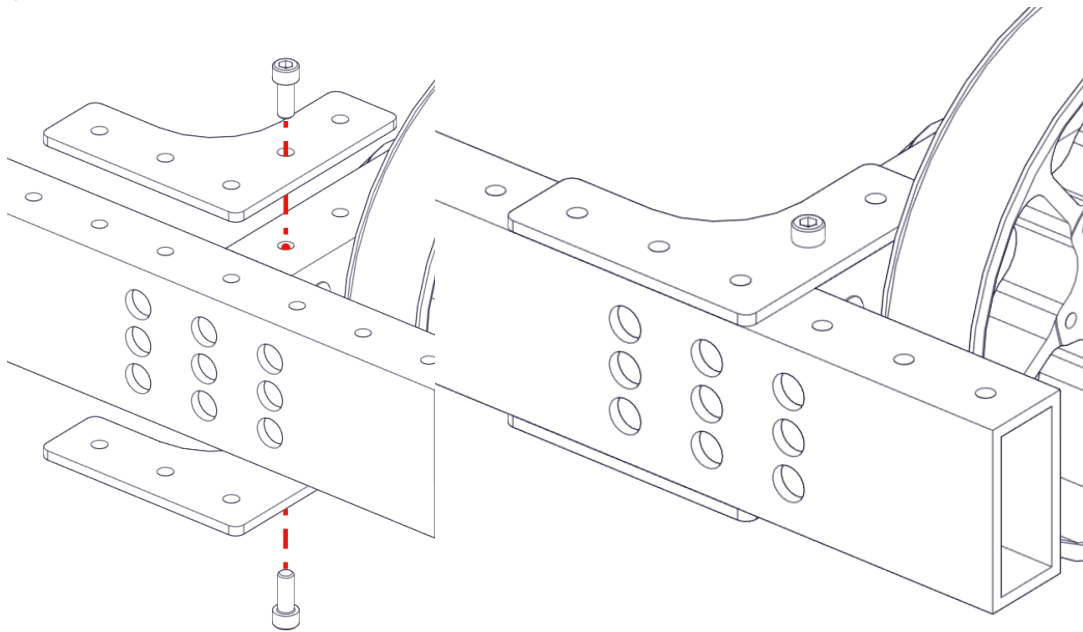

Step 3

Fully attach the 90° gussets with **four** 2.5" long 10-32 socket head cap screws (am-1024) and **four** 10-32 thin nylock nuts (am-1063.) **Sixteen** total of each should be used in this step. Ensure all screws connected to the drivetrain are properly tightened. The West Coast Drive Chassis is now complete.

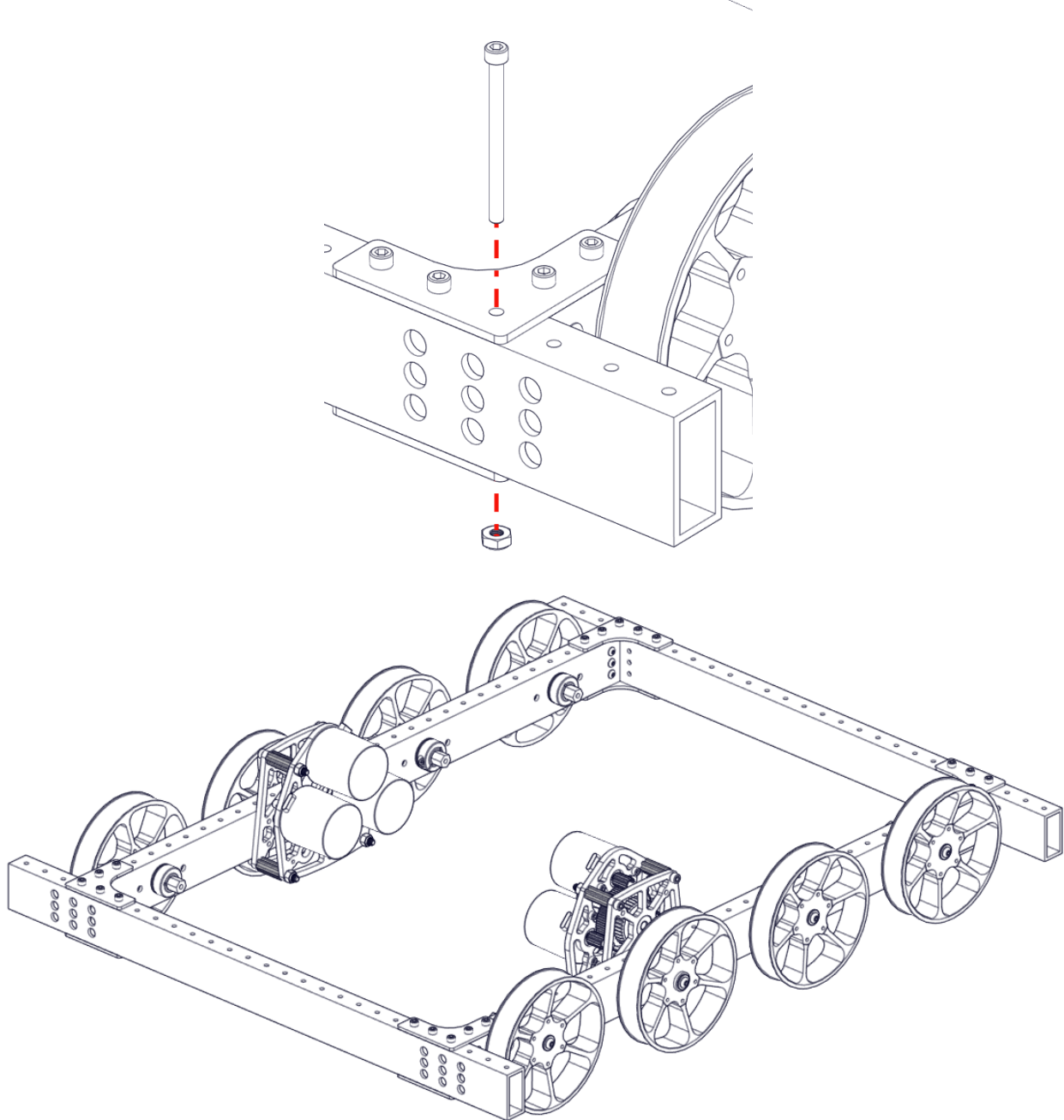

Appendices

Appendix A: Wheel Configurations

The West Coast Drive in a Box is compatible with any ½" hex bore wheel sold at AndyMark, but it is designed with the 4" / 6" HiGrip and 4" / 6" performance wheels in mind. The drive rails of the WCD can be inset further or outset further to support thicker or thinner wheels by simply adjusting the mounting point on the end rails.

HiGrip wheels and Performance wheels must both undergo a preparation process before they can be installed in a drivetrain.

Performance Wheels

AndyMark has put together a [helpful video](#) on exactly how to prepare your Performance Wheels to put on your robot.



HiGrip Wheels

To prepare a HiGrip wheel for use, you must install the Hex Hub adapter. Insert the Hex Hub Adapter (am-4124) through the center of the wheel. Use 6 10-12 threadforming hex head cap screws to secure the adapter to the wheel. The wheel assembly is now fully prepared for use.

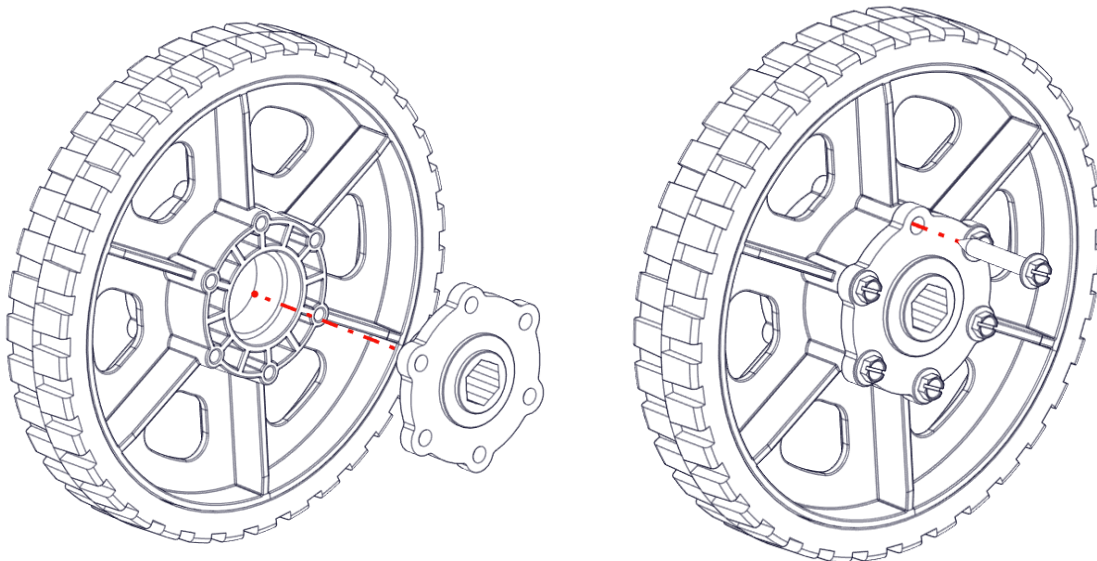

Appendix B: Gearbox Configurations

The AndyMark West Coast Drive Chassis is compatible with AndyMark's EVO Slim style of gearbox. In the chain-in-tube configuration, an EVO Slim with an appropriate length shaft can attach without modification. In the chain-out-of-tube configuration the WCD Variant of the EVO Slim must be used to accommodate the sprocket inside the gearbox. The correct version of the gearbox will be shipped with your chassis if ordered as a bundle.

EVO Slim

The EVO Slim can be constructed using the [EVO Slim assembly guide](#).



EVO Slim for WCD

The EVO Slim for WCD can be constructed using the [EVO Slim for WCD assembly guide](#).

